

OK-501-CAST IRON

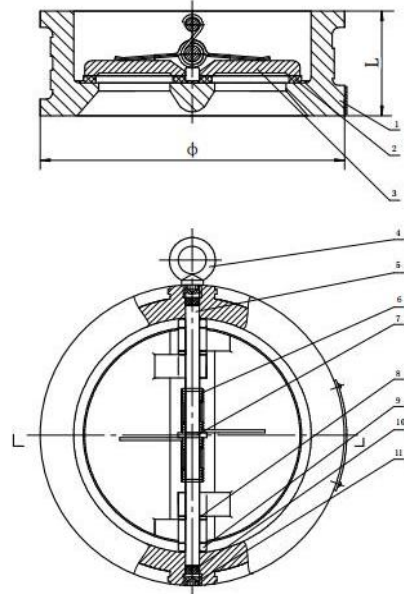

OK VALVE®
宏邦阀门

NO.	PART	Choose	QTY
1	BODY	CI/DI	1
2	SEAT	EPDM/NBR/VITON	1
3	DISC	DI+NP/CF8/CF8M/AL-B	2
4	EYE BOLT	SS304/SS316	1
5	SHAFT	SS304/SS316	2
6	SPRING	SS304/SS316	4
7	GASKET	F4	1
8	GASKET	F4	1
9	GASKET	F4	2
10	BUSH	F4	2
11	SCREW	SS304/SS316	4
TEST PRESSURE		SHELL	SEAL
HYDROSTATIC		2.4 MPa	1.76 MPa
STANDARD	DESIGN CODE	API 609/EN 593	
	INSPECTION & TEST	API 598/EN 12266	
	END STANDARD	PN10/16 150LB 10K	
	FACE TO FACE	API 609/EN 558	



GENERAL CHARACTERISTICS

Design in accordance with standard API609/EN 16767.

Range: From DN 40 to DN 600.

Mounting between flanges.

Working positions: horizontal and vertical ascending, and vertical descending position < DN 150.

Mounting in accordance with many standards connections.

Low head loss.

Stainless steel spring technology to avoid fluid hammer.

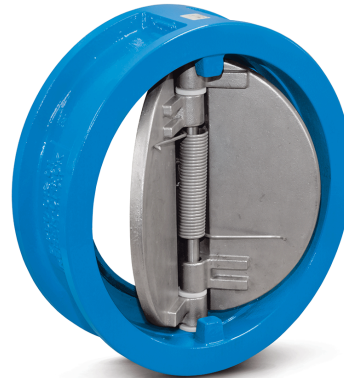

STANDARDS

Manufacture according to the requirements of the European directive 2014/68/EU «Equipment under pressure»:

category III modulate H.

Face to face according to standard API609/EN 558-1 serie 16.

Mounting with flanges PN10/PN16/150LB/10K from DN50 to DN600

Size	PN10/16		125LB		DN250-DN600 CONTACT
	L	φ C	L	φ C	φ C
2"/DN50					PN10/16 125LB 10K
2-1/2"/DN65					PN10/16 125LB 10K
3"/DN80					PN10/16 125LB 10K
4"/DN100					PN10/16 125LB 10K
5"/DN125					PN10/16 125LB 10K
6"/DN150					PN10/16 125LB 10K
8"/DN200					PN10/16 125LB 10K